



## F61 (6.8 Litre) Lubricator

Impco lubricators for pneumatic long-hole drills and diamond drills. Laser cut and Rugged welded construction airline lubricator featuring a large 63mm (2½") air inlet and twin 38mm (1½") outlets providing maximum air flow and volume.

Air is filtered through a stainless steel screen and rock drill oil is metered by separate needle point adjusting valves. No orifices to replace winter or summer.

A 6.8 litre (1.5 gallon) capacity, in-line-oiler providing controlled flow air misted rock drill oil at normal operating temperatures. A carry handle are fitted for easy transport of lubricator



### **Features**

Fitted with a safety Filler Cap that alerts the operator that the lubricator is pressurized

Laser cut and Rugged welded construction

6.8 litre (1.5 gallon) holding capacity

### **Technical Information**

	<b>Metric</b>	<b>Imperial</b>
Length	420 mm	16.5 Inches
Width	325 mm	12.8 inches
Height	246 mm	9.7 inches
Nett Weight	20 kg	44lb
Capacity	6.8 litre	1.5 gal

### **Ordering Numbers**

*F61 Lubricator*

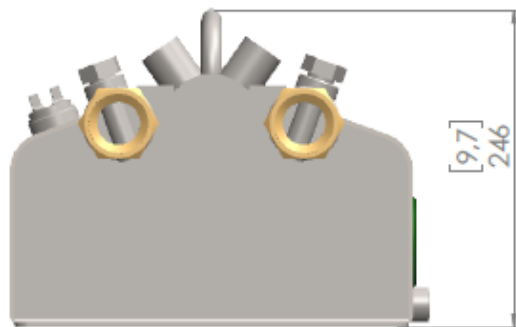
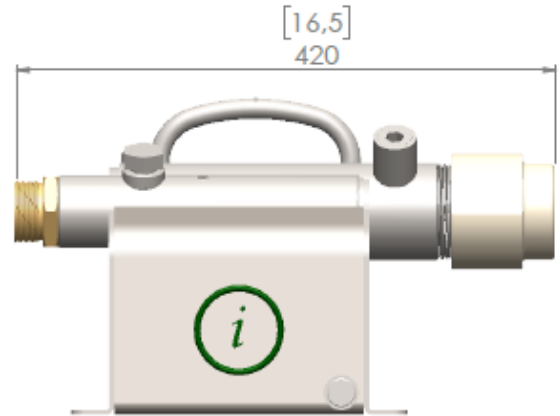
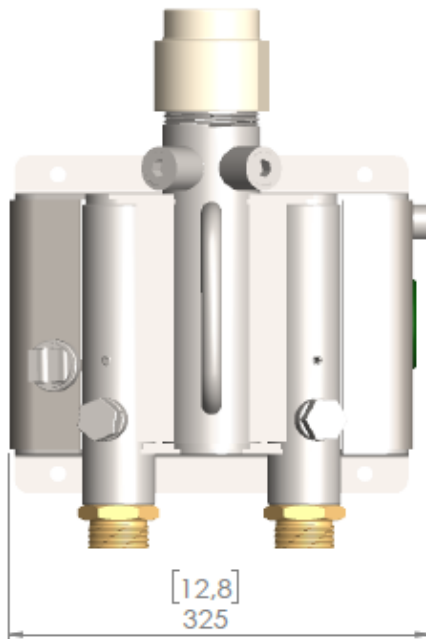

Impco Engineering carries a full range of parts for the F61 lubricator in stock. All parts made in South Africa in Our factory based in Rosslyn, Pretoria North to precise specifications using only the highest quality tool steel

**Notes**

---

---

---

---

---

---

---

---